

D12C-A MP, D12D-A MP, D12D-B MP, D12D-B MH

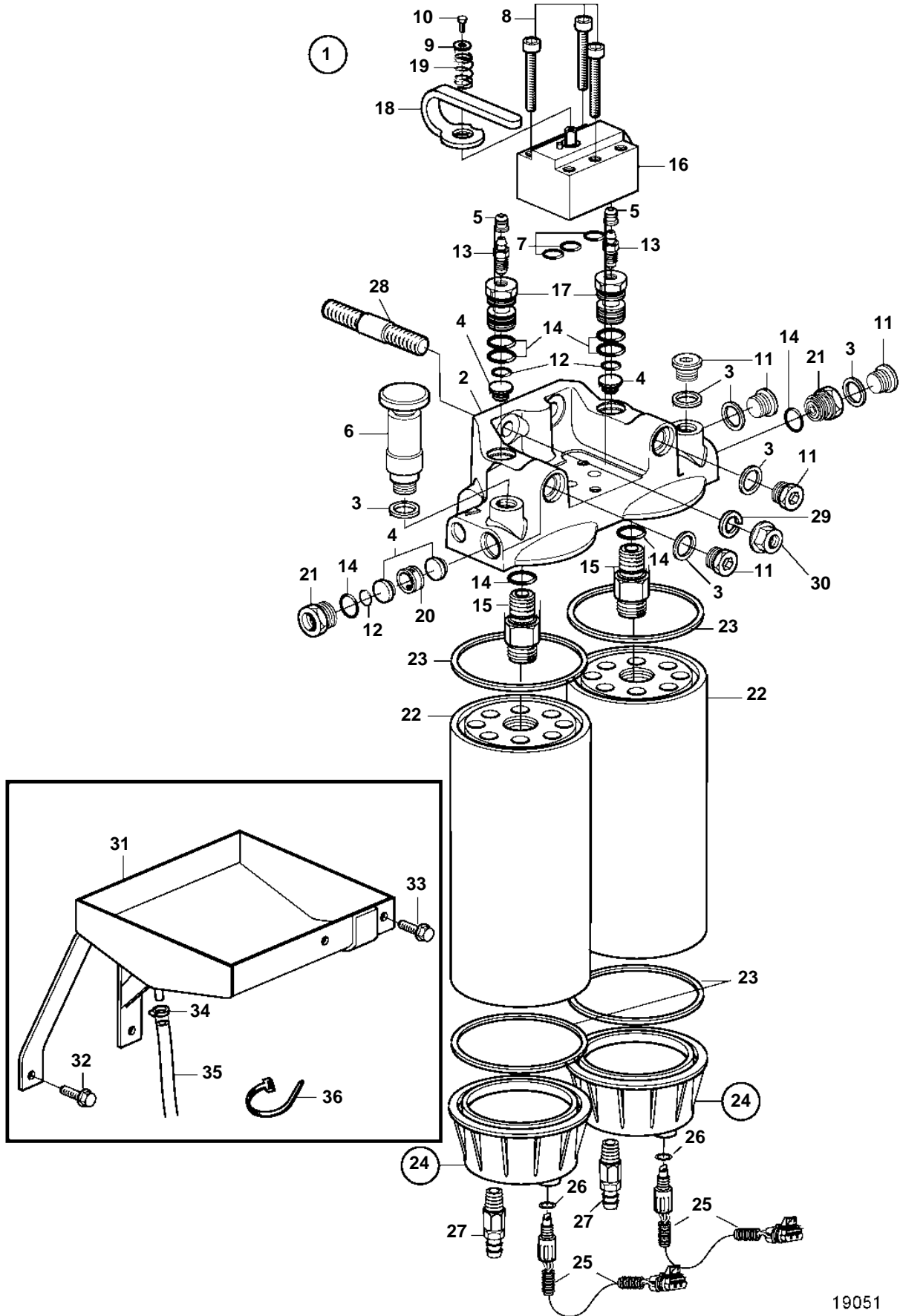

19051

D12C-A MP, D12D-A MP, D12D-B MP, D12D-B MH

REF	PART NO.	QTY	DESCRIPTION	NOTES
1		1	Filter housing	
2	3808691	1	· Filter housing	(3831048)
3	11996	5	· Gasket	
4	244834	4	· Valve	
5	20547976	2	· Protecting cover	(656456)
6	3837393	1	· Hand pump	
7	944364	3	· O-ring	
8	959227	3	· Screw	
9	960137	1	· Washer	
10	963537	1	· Screw	
11	966143	5	· Plug	
12	976971	3	· O-ring	
13	20548012	2	· Tap	(1330191)
14	1526474	8	· O-ring	
15	3831210	2	· Nipple	
16	3835369	1	· Valve body	
17	3835370	2	· Nipple	
18	3835371	1	· Handle	
19	3836027	1	· Compression spring	
20	3964717	1	· Spacer sleeve	
21	8148328	2	· Nipple	
22	3818517	2	Oil filling	(3828838)
23		2	· Gasket	
24	3836024	2	Bowl	
25	3588916	2	· Sender	(874109)
26	3831094	2	· · O-ring	
27	949918	2	· Drain cock	
28	977297	2	Stud	
29	941908	2	Spring washer	
30	971095	2	Nut	
31	3832639	1	Plate	
32	946440	3	Flange screw	
33	946173	2	Flange screw	For oil drain pump.
34	943472	1	Hose clamp	
35	941995	X	Rubber hose	L=400mm
36	948211	X	Strip clamp	